

Description

The DL3304P9 is a low capacitance high power TVS, utilizing leading monolithic silicon technology to provide fast response time and low ESD clamping voltage, making this device an ideal solution for protecting voltage sensitive high-speed data lines. The DL3304P9 complies with the IEC 61000-4-2 (ESD) standard with $\pm 30\text{kV}$ air and $\pm 30\text{kV}$ contact discharge. It is assembled into a 10-pin DFN3020-10 lead-free package. Each device will protect two line pairs high-speed lines. The combination of small size, low capacitance, and high surge capability makes them ideal for use in applications such as Gigabit Ethernet, telecommunication lines, and LVDS interfaces.

Mechanical Characteristics

- ◆ Package: DFN3020-10
- ◆ Case Material: "Green" Molding Compound.
- ◆ Moisture Sensitivity: Level 3 per J-STD-020
- ◆ Terminal Connections: See Diagram Below
- ◆ Marking Information: See Below

Dimensions and Pin Configuration

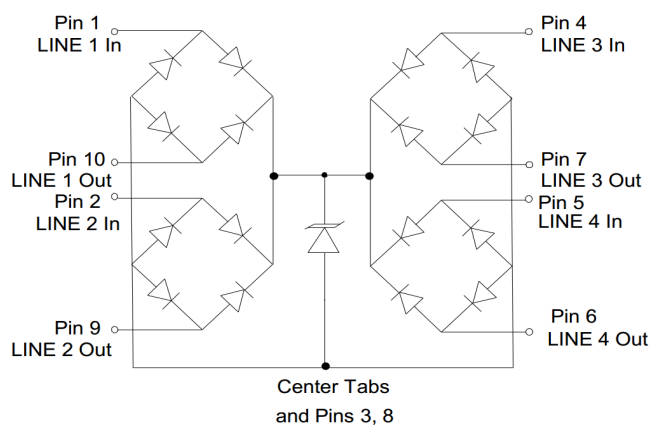

Circuit Schematic

Features

- ◆ Low capacitance: 1.7pF typical(I/O to I/O)
- ◆ Ultra low leakage: nA level
- ◆ Operating voltage: 3.3V
- ◆ Ultra low clamping voltage
- ◆ Protects up to eight lines
- ◆ Complies with following standards:
 - IEC 61000-4-2 (ESD) immunity test Air discharge: $\pm 30\text{kV}$
 - Contact discharge: $\pm 30\text{kV}$
 - IEC 61000-4-5 (Lightning) 40A (8/20 μs)
- ◆ RoHS Compliant

Marking Information

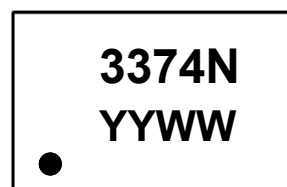

3374N = Device Marking Code
Dot denotes pin1

Applications

- ◆ LVDS Interfaces
- ◆ 10/100/1000 Ethernet
- ◆ Notebooks, Desktops, Servers
- ◆ Networking Equipment
- ◆ Switching Systems
- ◆ Audio/Video Inputs

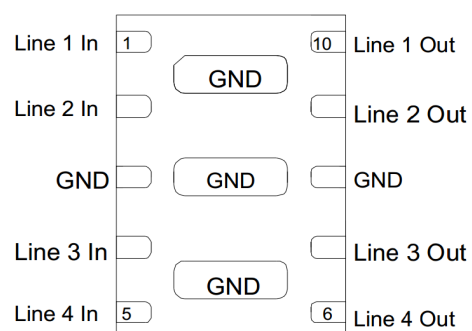

Pin Schematic

Ordering Information

Part Number	Marking	Packaging	Reel Size
DL3304P9	3374N/YYWW	3000/Tape & Reel	7 inch

Absolute Maximum Ratings ($T_A=25^{\circ}\text{C}$ unless otherwise specified)

Parameter	Symbol	Value	Unit
Peak Pulse Power(8/20 μs)	Ppk	1000	W
Peak Pulse Current(8/20 μs)	Ipp	40	A
ESD per IEC 61000-4-2 (Air)	VESD	± 30	kV
ESD per IEC 61000-4-2 (Contact)		± 30	
Operating Temperature Range	TJ	-55 to +125	$^{\circ}\text{C}$
Storage Temperature Range	Tstg	-55 to +150	$^{\circ}\text{C}$

Electrical Characteristics ($T_A=25^{\circ}\text{C}$ unless otherwise specified)

Parameter	Symbol	Min	Typ	Max	Unit	Test Condition
Reverse Working Voltage	VRWM			3.3	V	
Punch-Through Voltage	VPT	3.5			V	IT = 2 μA
Snap-Back Voltage	VSB	2.8			V	ISB = 50mA
Reverse Leakage Current	IR			0.5	μA	VRWM = 3.3V
Clamping Voltage	VC			5.5	V	I _{PP} = 1A (8 x 20 μs pulse), any I/O pin to ground
Clamping Voltage	VC			10.5	V	I _{PP} = 10A (8 x 20 μs pulse), any I/O pin to ground
Clamping Voltage	VC			18	V	I _{PP} = 25A (8 x 20 μs pulse), any I/O pin to ground
Clamping Voltage	VC			25	V	I _{PP} = 40A (8 x 20 μs pulse), line to line (two I/O pins connected together on each line)
Junction Capacitance	CJ		1.7	2.5	pF	VR = 0V, f = 1MHz, between I/O pins
Junction Capacitance	CJ		3.8	5.0	pF	VR = 0V, f = 1MHz, any I/O pin to ground

Typical Performance Characteristics (TA=25°C unless otherwise Specified)

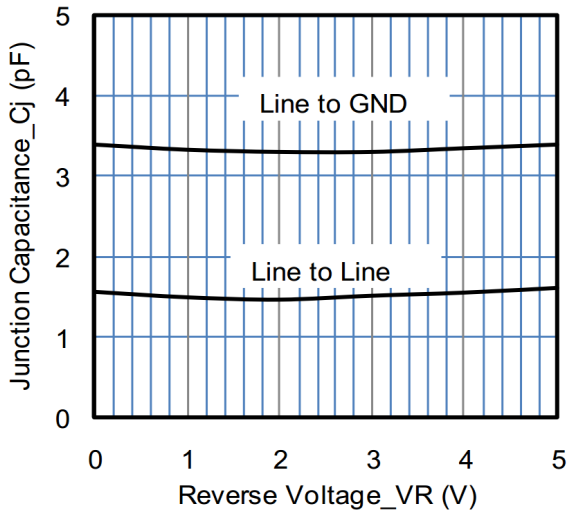

Junction Capacitance vs. Reverse Voltage

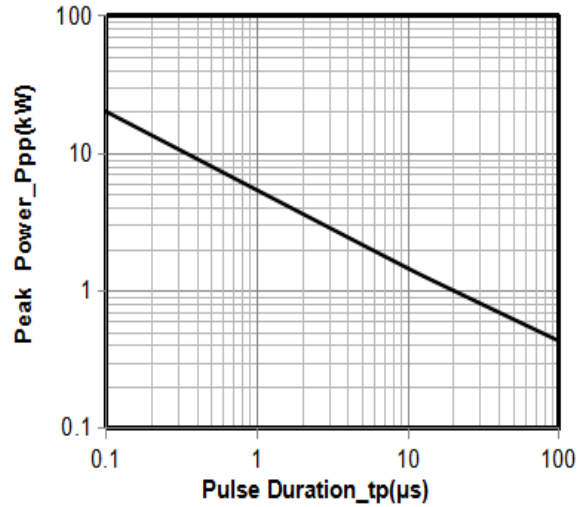

Peak Pulse Power vs. Pulse Time

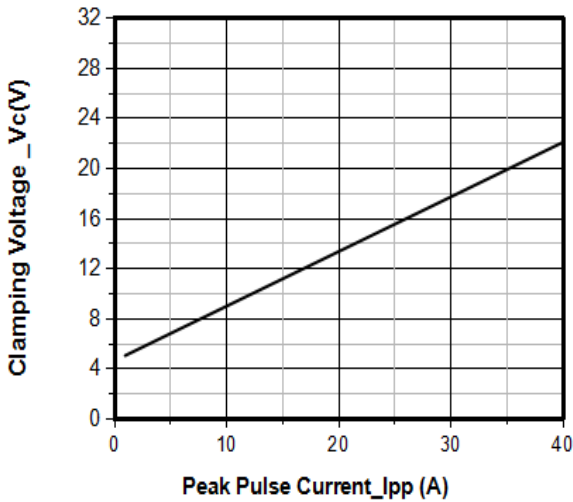

Clamping Voltage vs. Peak Pulse Current

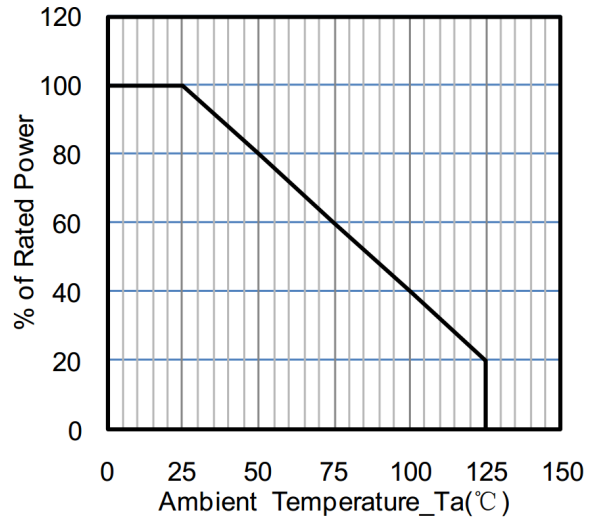

Power Derating Curve

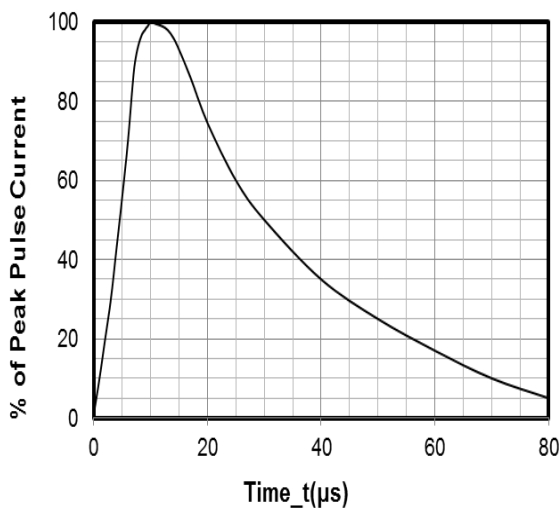

8 X 20 s Pulse Waveform

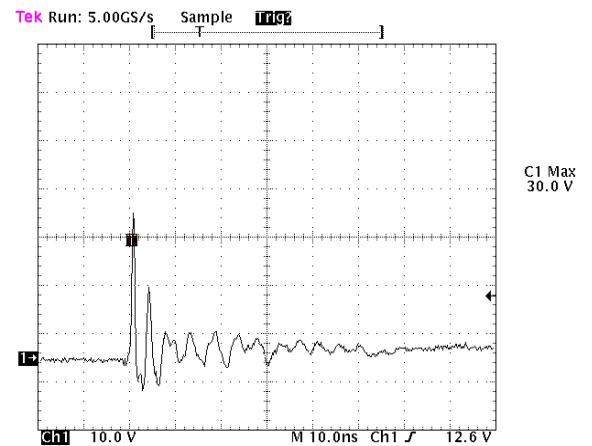

Note: Data is taken with a 10x attenuator

ESD Clamping Voltage
8 kV Contact per IEC61000-4-2

Typical Application

Electronic equipment is susceptible to damage caused by a variety of sources, including Electrostatic Discharge(ESD), Electrical Fast Transients(EFT) and Lightning strikes. The DL3304P9 is designed to protect the sensitive equipment from damage which may be induced by such transient events. This product can be configured in different connections to meet the requirement of common-mode and differential-mode.

DL3304P9 on Gigabit Ethernet Application

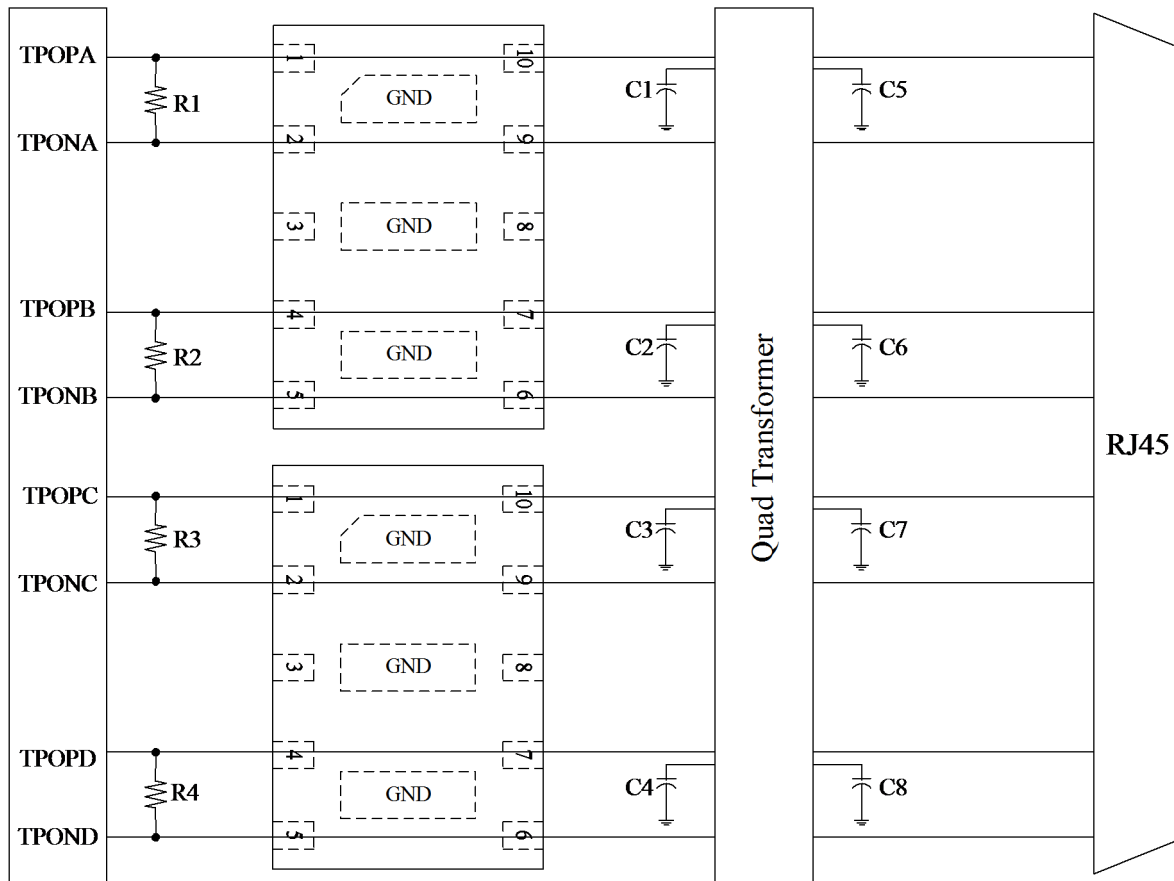

DFN3020-10 Package Outline Drawing

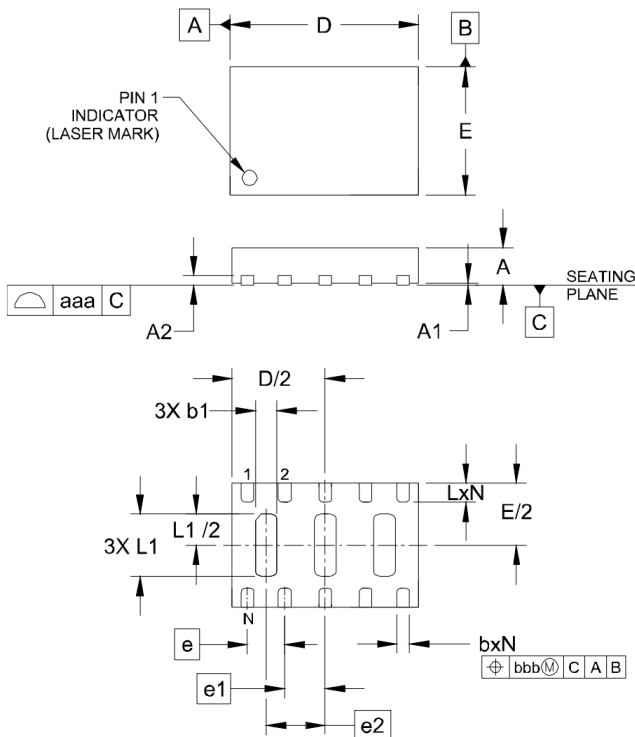

DIM	MILLIMETERS		
	MIN	NOM	MAX
A	0.50	0.60	0.65
A1	0.00	0.03	0.05
A2	(0.15)		
b	0.15	0.20	0.25
b1	0.25	0.35	0.45
D	2.90	3.00	3.10
E	1.90	2.00	2.10
e	0.60 BSC		
e1	0.65 BSC		
e2	0.95 BSC		
L	0.25	0.30	0.35
L1	0.95	1.00	1.05
N	10		
aaa	0.08		
bbb	0.10		

Suggested Land Pattern

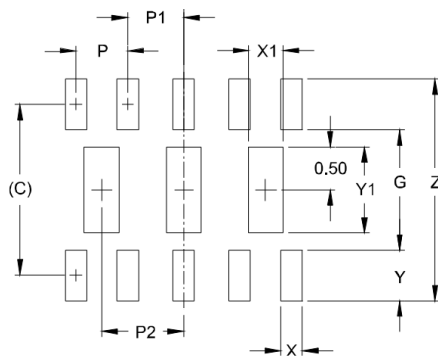

DIMENSIONS	
DIM	MILLIMETERS
C	(1.98)
G	1.40
P	0.60
P1	0.65
P2	0.95
X	0.25
X1	0.40
Y	0.58
Y1	1.00
Z	2.56

Contact Information

Changzhou D-first Electronics CO.,Ltd.

www.first-electronic.com

Email: xhf@first-electronic.cn

Phone: +86 (0519) 8817 1671